



***Impact Study
For
Generation Interconnection
Request
GEN-2006-034***

SPP Tariff Studies

(#GEN-2006-034)

June 2007

Summary

Pursuant to the tariff and at the request of the Southwest Power Pool (SPP), Pterra Consulting (Pterra) conducted the following Impact Study to satisfy the Impact Study Agreement executed by the requesting customer and SPP for SPP Generation Interconnection request GEN-2006-034. The request for interconnection was placed with SPP in accordance SPP's Open Access Transmission Tariff, which covers new generation interconnections on SPP's transmission system.

Facilities

The Impact Study determined that no SVC or STATCOM device was necessary for the requested generation using the General Electric wind turbines using the manufacturer's LVRT II package for low voltage ride through. The LVRT II package allows the wind turbine generator bus voltage to withstand voltages down to 0.15pu for up to 0.625 seconds. However, it was determined that a 34.5kV, 5Mvar capacitor bank is necessary for reactive compensation at the point of interconnection.

Facility estimates were given in the Feasibility Study. With the exception of the above mentioned capacitor bank, no new facilities were required by the Impact Study. The Facility estimates given in the Feasibility Study are restated below in Table 1 and Table 2. These costs will be refined if the Customer executes a Facility Study Agreement. These costs do not include facilities that may be required after a fault study analysis. This analysis will be conducted if the Customer executes a Facility Study Agreement.

Table 1: Direct Assignment Facilities

Facility	ESTIMATED COST (2007 DOLLARS)
Customer – 115-34.5 kV Substation facilities.	*
Customer – 115kV transmission line facilities between Customer facilities and the new 115kV ring bus.	*
Customer - Right-of-Way for Customer facilities.	*
Customer – 34.5kV, 5Mvar capacitor bank in Customer substation.	*
Total	*

Note: *Estimates of cost to be determined by Customer.

Table 2: Required Interconnection Network Upgrade Facilities

Facility	ESTIMATED COST (2006 DOLLARS)
SUNC – Build 115kV, 3 breaker ring bus switching station. Station to include breakers, switches, control relaying, high speed communications, metering and related equipment and all structures.	\$750,000
Total	\$750,000

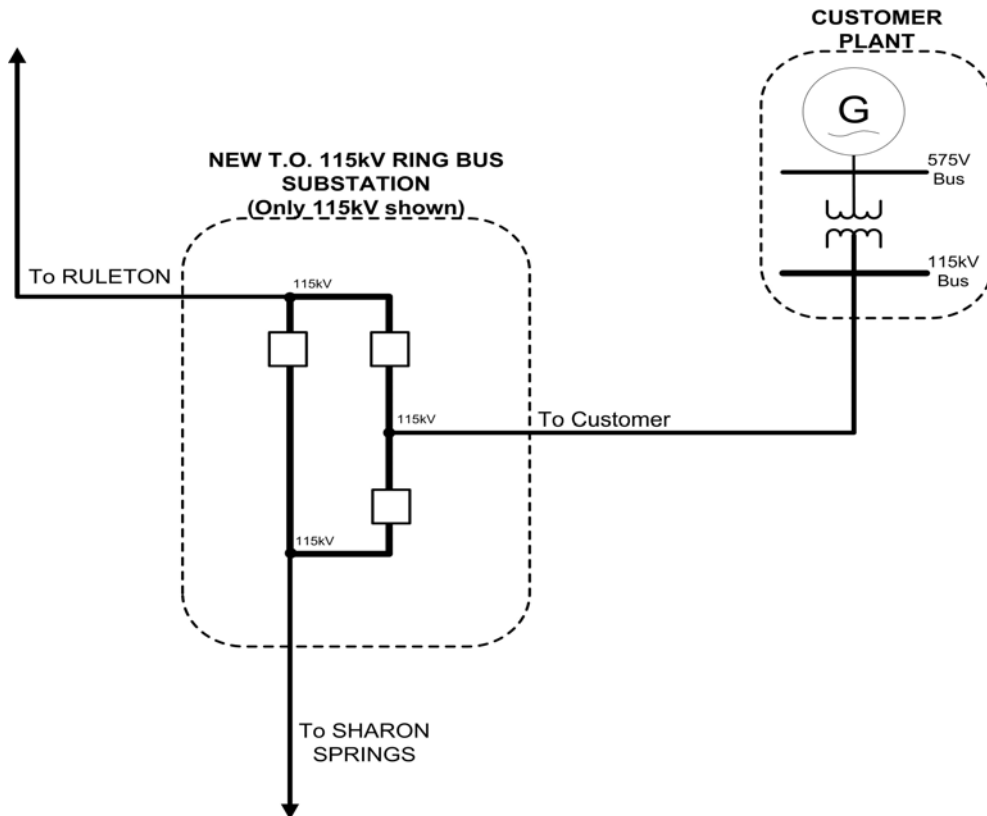

FIGURE 1. ONE-LINE OF THE INTERCONNECTION

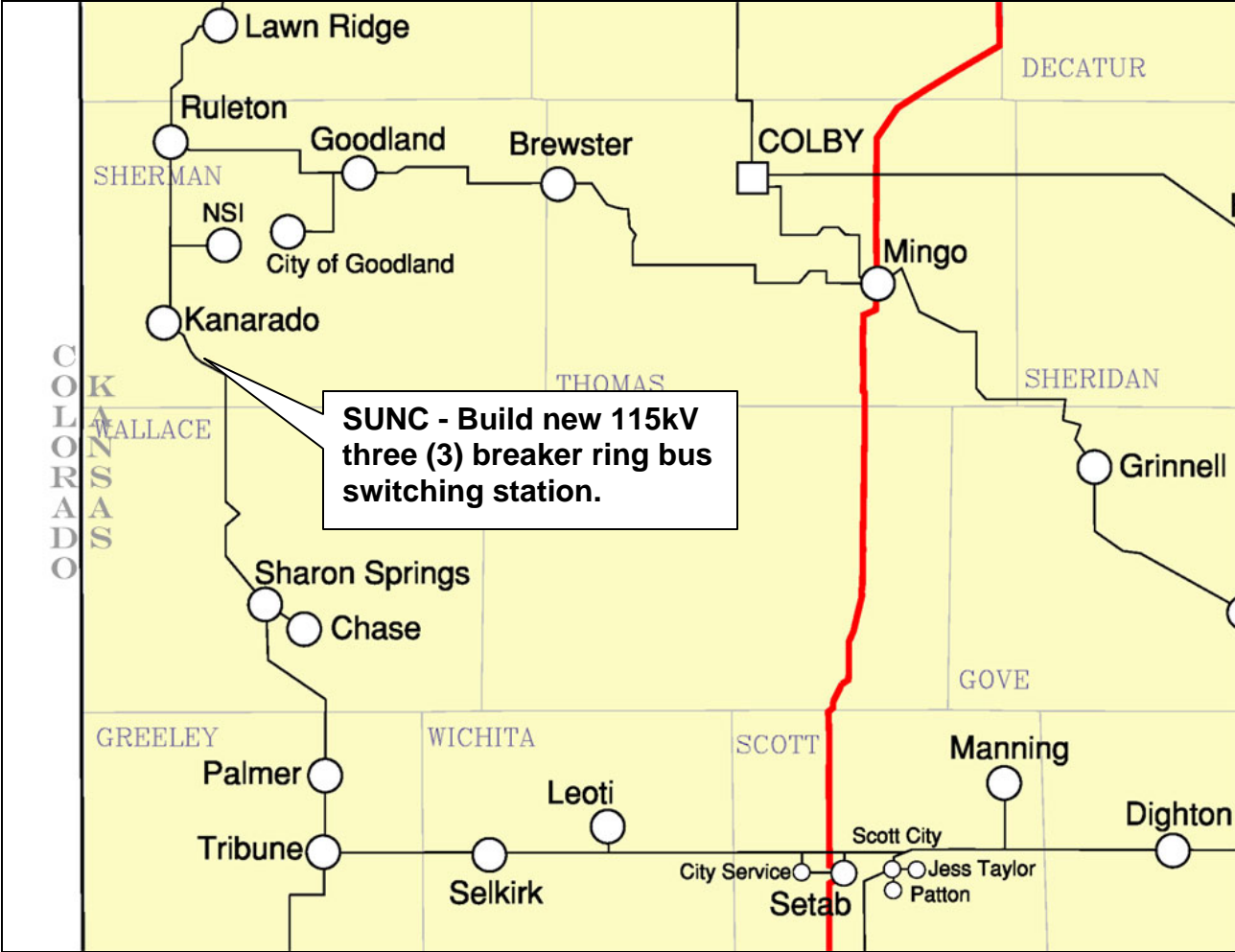

FIGURE 2. MAP OF THE LOCAL AREA

Pterra Consulting

Report No. R117-07

“Impact Study for Generation Interconnection Request GEN-2006-034”

Submitted to

The Southwest Power Pool

June 2007



4 Automation Lane, Ste.250, Albany, NY 12205 Tel: 518-724-3832 Web: www.pterra.us

Report No. R117-07

‘Impact Study for Generation Interconnection Request GEN- 2006-034’

1. Executive Summary	1
2. Introduction	3
2.1 Project Overview	3
2.2 Objective	6
3. Stability Analysis	8
3.1 Modeling of the General Electric 1.5 MW Wind Turbine Generators .	8
3.2 Assumptions	11
3.3 Disturbances Simulated.....	12
3.5 Simulation Results	16
4. Conclusion	17
Appendix A. Project Data	19

1. Executive Summary

This report presents the stability simulation findings of the impact study of a proposed interconnection (GEN-2006-034). The analysis was conducted through the Southwest Power Pool Tariff for a 115 kV interconnection for 81 MW wind farm in Sherman County, Kansas. This generating facility will be interconnected electrically into a new 115 kV ring bus along the Ruleton-Sharon Springs 115 kV line on Sunflower Electric Power Corp. (SUNC) transmission system. The customer has asked for an impact study case of 100% MW. GE 1.5 MW wind turbine generators (WTGs) were studied according to the customer's request.

Two base cases each comprising of a power flow and corresponding dynamics database for 2007 summer peak and 2011 winter peak were provided by SPP. Transient stability simulations were conducted with the proposed wind farm in service with a full output of 81 MW. In order to integrate the proposed 81 MW wind farm in SPP system, the existing generation in the SPP footprint was re-dispatched as provided by SPP. Unity power factor at the interconnection point was achieved by using 5 MVAR capacitor located on the 34.5kV customer side.

Twelve (12) disturbances were considered for the transient stability simulations which included 3-phase faults as well as 1-phase to ground faults at the locations defined by SPP.

The proposed GE WTGs were modeled with under/over voltage/frequency ride through protection package II. The settings were in accordance with standard or default settings. The simulations conducted in the study using the GE 1.5 MW WTGs did not find any angular or voltage instability problems for the twelve disturbances. The study finds that the proposed 81 MW project shows stable performance of SPP system for the contingencies tested on the supplied base cases.

2. Introduction

2.1 Project Overview

The proposed 81 MW wind farm will be interconnected electrically into a new 115 kV ring bus along the Ruleton-Sharon Springs 115 kV line on Sunflower Electric Power Corp. (SUNC) transmission system. Figure 1 shows a conceptual interconnection diagram of the proposed GEN-2006-034 project to the 115 kV sub-transmission network. The detailed connection diagram of the wind farm was provided by SPP.

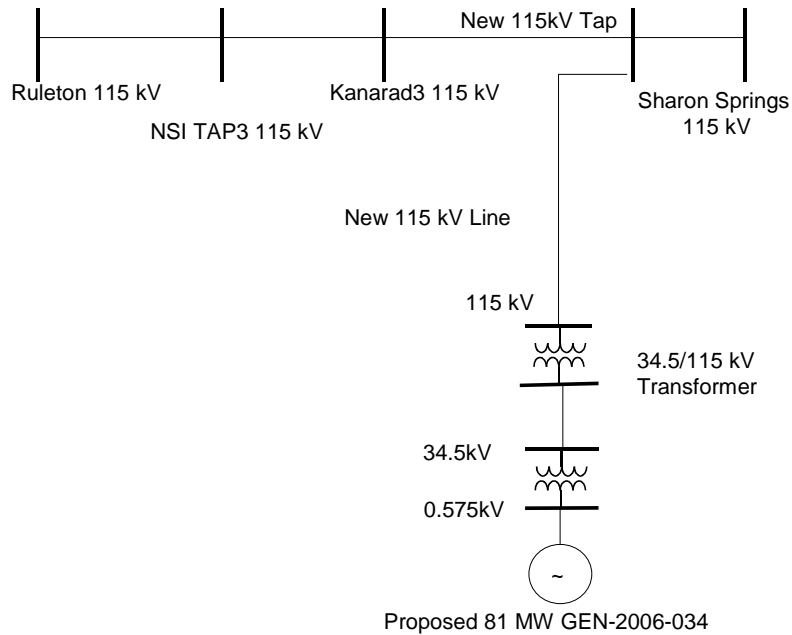

Figure 1. Interconnection Plan for GEN-2006-034 to the 115 kV System

In order to integrate the proposed 81 MW wind farm in SPP system as an Energy Resource, existing generation in the SPP footprint is displaced.

To simplify the model of the wind farm while capturing the effect of the different impedances of cables (due to change of the conductor size and length), the wind turbines connected to the same 34.5kV feeder were aggregated into one equivalent unit. An equivalent impedance of that feeder was represented by taking the equivalent series impedances of the different feeders connecting the wind turbines. Using this approach, the proposed 81 MW wind farm was modeled with 29 equivalent units as shown in Figure 2. The number in each circle in the diagram shows the number of individual wind turbine units that were aggregated at that bus. SPP provided the impedance values for the different feeders at 34.5kV level. SPP provided the data for the following equipment:

1. 34.5 kV feeders
2. Generating unit step up transformers
3. 115/34.5 kV transformers
4. 115 kV line from the high side of 115/34.5 kV transformers (mentioned above) to the point of interconnection.

Unity power factor was achieved at the interconnection point using 5 MVAR capacitor located at the 34.5 kV side of the 115/34.5 kV Transformer.

2.2 Objective

The objective of the study is to determine the impact on system stability of connecting the proposed 81 MW wind farm to SPP's 115 kV sub-transmission system.

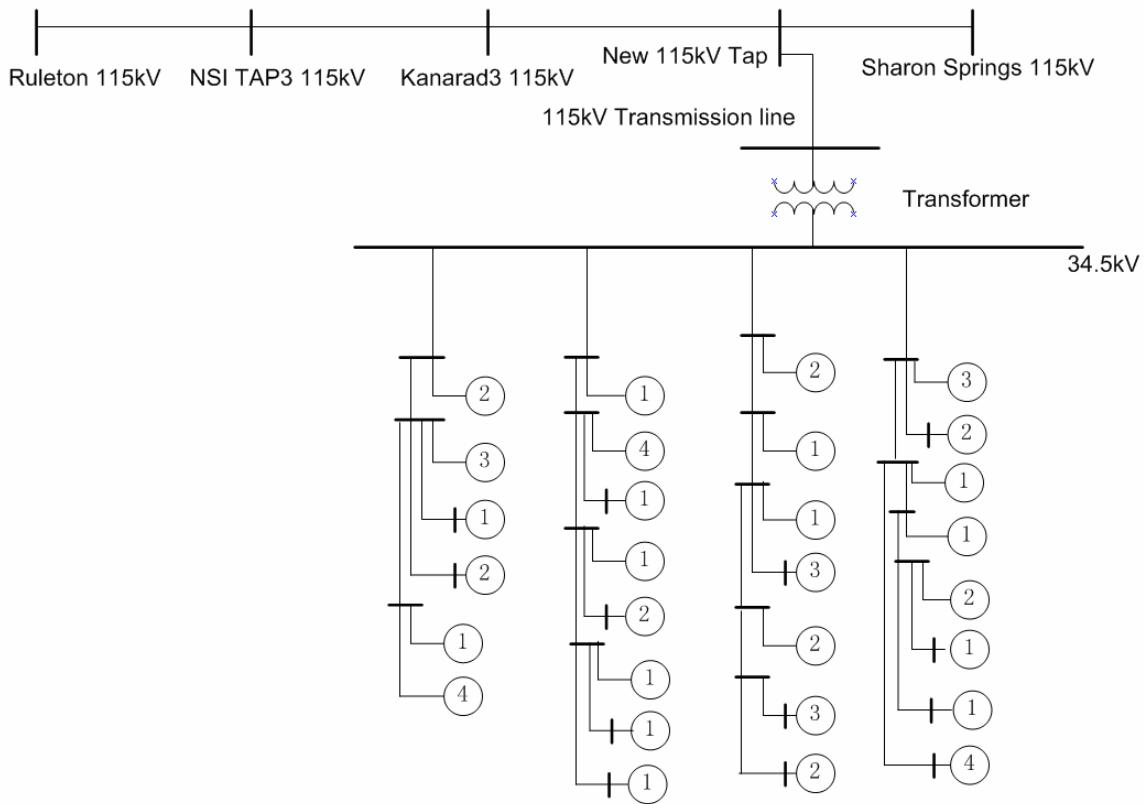

Figure 2. Wind Farm Model in Load Flow (54 GE 1.5 MW WTGs or Total of 81 MW)

3. Stability Analysis

3.1 Modeling of the General Electric 1.5 MW Wind Turbine Generators

Equivalents for the wind turbine and generator step-up (GSU) transformer in the load flow case were modeled. For the stability simulations, the GE 1.5 MW WTGs were modeled using the provided GE 1.5 MW wind turbine dynamic model set, as shown in Table 1.

Table 1. GE 1.5 MW WTGs Data

Parameter	Value
BASE KV	0.575
WTG MBASE	1.667
TRANSFORMER MBASE	1.750
TRANSFORMER R ON TRANSFORMER BASE	0.0077
TRANSFORMER X ON TRANSFORMER BASE	0.0579
GTAP	1.0
PMAX (MW)	1.5
PMIN(MW)	0.0
XEQ, PU	0.8
LA	0.1714
LM	2.904
R1	0.005
L1	0.1563
INERTIA	0.558
DAMPING	0.0
QMAX(MVAR)	0.490
QMIN(MVAR)	-0.730

The wind turbine generators have ride-through capability for voltage and frequency. Detailed relay settings are shown in the following tables:

Table 2. Over/Under Frequency Relay Settings for GE 1.5 MW WTGs

Frequency Settings in Hertz	Time Delay in Seconds	Breaker time in Seconds
$f \leq 56.5$	0.02	0.08
$56.5 < f \leq 57.5$	10	0.08
$61.5 \leq f < 62.5$	30	0.08
$f \geq 62.5$	0.02	0.08

Table 3. Over/Under Voltage Relay Settings for GE 1.5 MW WTGs

Voltage Settings Per Unit	Time Delay in Seconds	Breaker time in Seconds
$V \leq 0.15$	0.625	0.08
$0.15 < V \leq 0.70$	0.625	0.08
$0.70 < V \leq 0.75$	1.0	0.08
$0.75 < V \leq 0.85$	10	0.08
$1.1 < V \leq 1.15$	1.0	0.08
$1.15 < V \leq 1.3$	0.1	0.08
$V \geq 1.3$	0.02	0.08

3.2 Assumptions

The following assumptions were adopted for the study:

1. Constant maximum and uniform wind speed for the entire period of study
2. Wind turbine control models with their default values
3. Under/over voltage/frequency protection set to standard manufacturer data

3.3 Disturbances Simulated

Twelve (12) disturbances were considered for the transient stability simulations which included three phase faults as well as single phase line faults at the locations defined by SPP. Single-phase line faults were simulated by applying a fault impedance to the positive sequence network at the fault location to represent the effect of the negative and zero sequence networks on the positive sequence network. The fault impedance was computed to give a positive sequence voltage at the specified fault location of approximately 60% of pre-fault voltage. This method is in agreement with SPP current practice. Table 4 shows the list of simulated disturbances. The table also shows the fault clearing time and the time delay before re-closing for all the study disturbances.

Table 4. List of Simulated Disturbances

<p>1. FLT13PH – 3-phase fault Fault on the Wind Farm (90800) to Ruleton (56357) 115 kV line, near the Wind Farm</p> <ol style="list-style-type: none">Apply Fault at the Wind Farm bus (90800).Clear Fault after 5 cycles by removing the line from the Wind Farm - RuletonWait 20 cycles, and then re-close the line in (b) back into the fault.Leave fault on for 5 cycles, then trip the line in (b) and remove fault.
<p>2. FLT21PH – 1-phase fault</p> <ul style="list-style-type: none">Same as FLT13PH above
<p>3. FLT33PH – 3-phase fault Fault on the Wind Farm (90800) to Sharon Springs (56358) 115 kV line, near the Wind Farm</p> <ol style="list-style-type: none">Apply Fault at the Wind Farm bus (90800).Clear Fault after 5 cycles by removing the line from Wind Farm – Sharon Springs (56358).Wait 20 cycles, and then re-close the line in (b) back into the fault.Leave fault on for 5 cycles, then trip the line in (b) and remove fault.
<p>4. FLT41PH – 1-phase fault</p> <ul style="list-style-type: none">Same as FLT33PH above
<p>5. FLT53PH – 3-phase fault Fault on the Ruleton (56357) to Lawn Ridge (56368) 115 kV line, near Ruleton</p> <ol style="list-style-type: none">Apply Fault at the Ruleton bus (56357).Clear Fault after 5 cycles by removing the line from Ruleton-Lawn RidgeWait 20 cycles, and then re-close the line in (b) back into the fault.Leave fault on for 5 cycles, then trip the line in (b) and remove fault.
<p>6. FLT61PH – 1-phase fault</p> <ul style="list-style-type: none">Same as FLT53PH above.

7. FLT73PH – 3-phase fault

Fault on the Ruleton (56357) to Goodland (56443) 115 kV line, near Ruleton

- a. Apply Fault at the Ruleton bus (56357).
- b. Clear Fault after 5 cycles by removing the line from Ruleton-Goodland
- c. Wait 20 cycles, and then re-close the line in (b) back into the fault.
- d. Leave fault on for 5 cycles, then trip the line in (b) and remove fault.

8. FLT81PH – 1-phase fault

- Same as FLT73PH above

9. FLT93PH – 3-phase fault

Fault on the Tribune Switch (56438) to Selkirk (56434) 115 kV line, near Tribune Switch

- a. Apply Fault at the Tribune Switch bus (56438).
- b. Clear Fault after 5 cycles by removing the line from Tribune Switch - Selkirk
- c. Wait 20 cycles, and then re-close the line in (b) back into the fault.
- d. Leave fault on for 5 cycles, then trip the line in (b) and remove fault.

10. FLT101PH – 1-phase fault

- Same as FLT93PH above

11. FLT93PH – 3-phase fault

Fault on the Tribune (56439) to Syracuse (56437) 115 kV line, near Tribune

- a. Apply Fault at the Tribune bus (56439).
- b. Clear Fault after 5 cycles by removing the line from Tribune - Syracuse
- c. Wait 20 cycles, and then re-close the line in (b) back into the fault.
- d. Leave fault on for 5 cycles, then trip the line in (b) and remove fault.

12. FLT121PH – 1-phase fault

- Same as FLT113PH above.

3.5 Simulation Results

Simulations were performed with a 0.5-second steady-state run followed by the appropriate disturbance as described in Table 4. Simulations were run for a minimum 10-second duration to confirm proper machine damping.

The results of the stability simulations, for the disturbances listed in Table 4, did not find any angular or voltage instability problems with the GE 1.5 MW WTGs.

For the two base cases with the proposed 81 MW wind farm in service, a complete set of the transient stability plots are provided in the accompanying CD-ROM. The plots include rotor angle, speed, frequency, and voltages for the monitored buses and machines in the SPP.

4. Conclusion

The stability simulation findings of the impact study of a proposed interconnection (GEN-2006-034) were presented in this report. The impact study case considered 100% MW of the wind farm proposed output. GE 1.5 MW WTGs were studied according to the customer request.

The 2007 summer and 2011 winter load flow cases together with the necessary data needed for the transient stability simulations were provided by SPP. Transient stability simulations were conducted with the proposed wind farm in service with a full output of 81 MW. In order to integrate the proposed 81 MW wind farm in SPP system, re-dispatch for the existing SPP footprint generation was provided by SPP. Unity power factor at the interconnection point was achieved by adding 5 MVAR capacitor at the 34.5kV side of the project substation.

Twelve (12) disturbances were considered for the transient stability simulations which included three phase faults as well as single line to ground faults at the locations defined by SPP.

The results of the stability simulations for the studied disturbances did not find any angular or voltage instability problems with the GE 1.5 MW WTGs. The study finds that the proposed 81 MW project shows stable performance of SPP system for the contingencies tested on the supplied base cases.

Appendix A. Project Data